

iDeal

aluminum

iDEALRAIL

SIMPLIFYING THE RAILING INDUSTRY

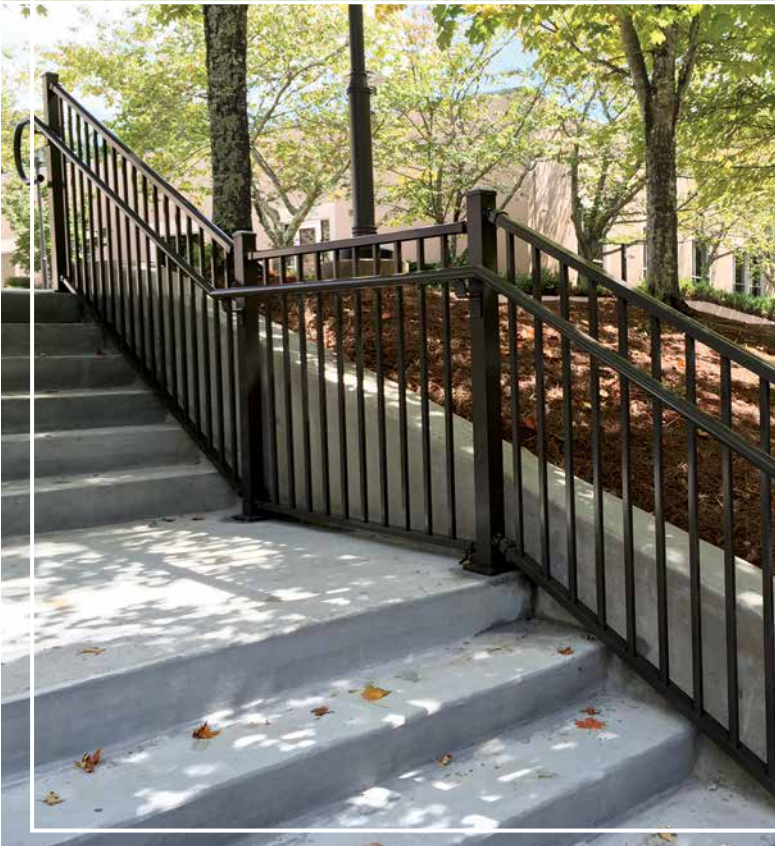

IDEALRAIL DETAILS

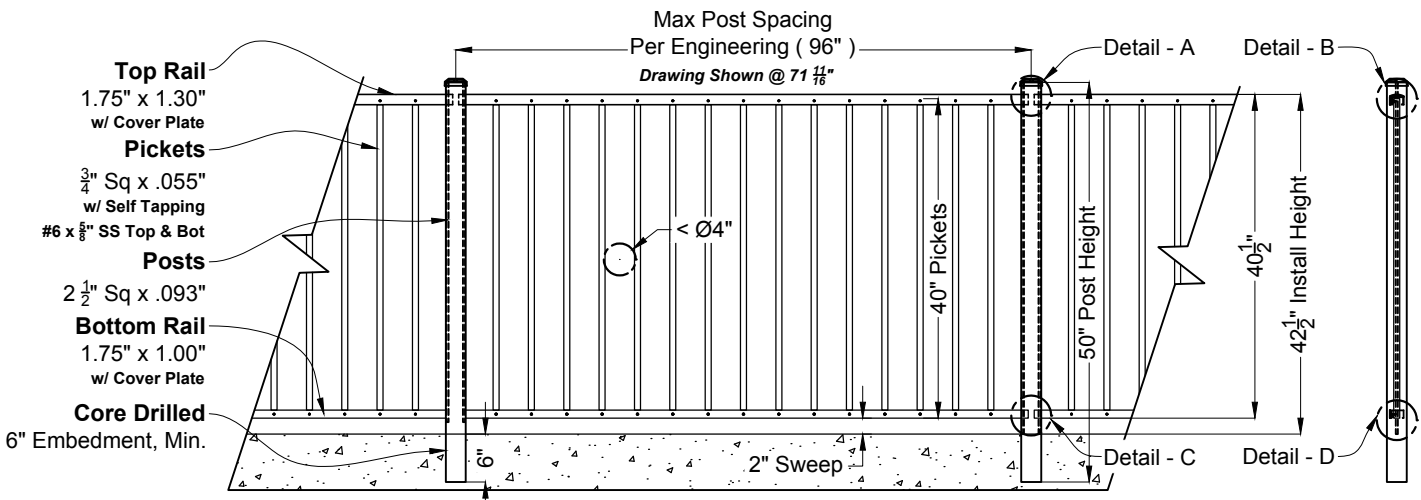
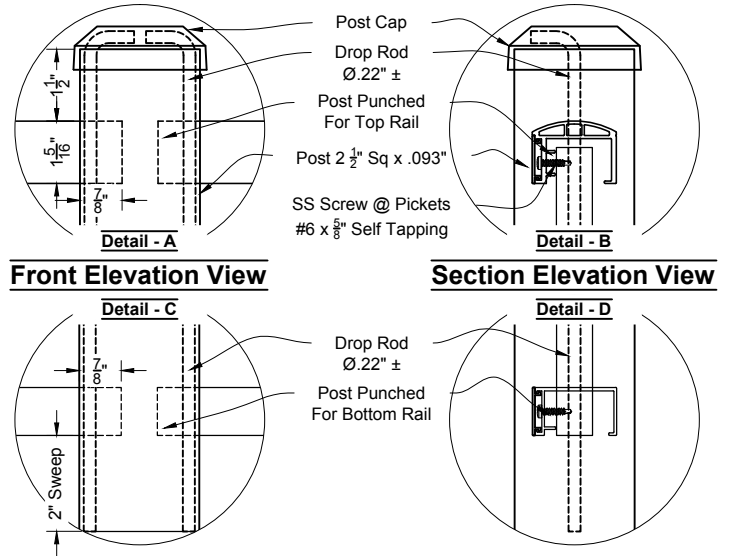
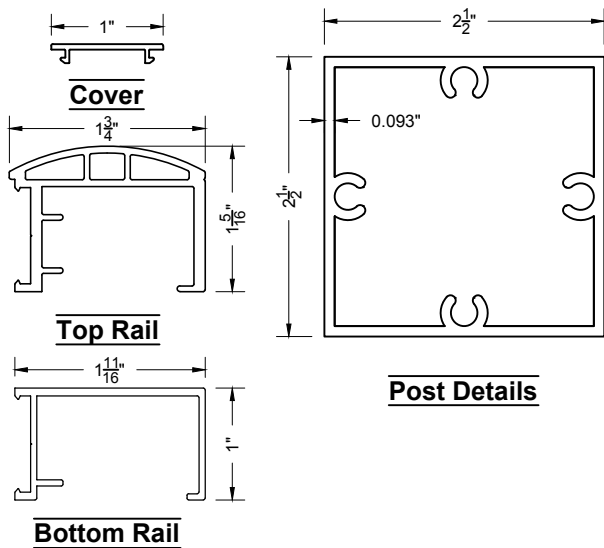

- **Strength is in the engineering:** iDEALRAIL was designed to span an industry leading 8' between posts due to a dual wing top rail and 2-1/2" posts with mechanical flanges.
- **Eliminate complicated stair measurements:** iDEALRAIL will rack up to 40 degrees to accommodate most stair and ramp applications.
- **Eliminate lead times:** iDEALRAIL can be customized in the field to fit all of your projects and stocked in 6' wide and 8' wide preassembled sections.
- **Concealed fasteners:** iDEALRAIL uses our patented snap plate technology to conceal the entire picket to rail connections. Post connections are made internally through a routed post and locking rod.



STANDARD COLORS



iDeal
aluminum

www.ideal-ap.com
Toll Free: 877.323.6496
Fax: 877.226.4469

ALL PRODUCTS
PROUDLY
MADE IN
USA